

## Technical Sheet

### Heat recovery appliance Renovent Excellent 400 (Plus)



The Brink Renovent Excellent is a ventilation unit with heat recovery with an efficiency of 95%, a maximum ventilation capacity of 300 or 400 m<sup>3</sup>/h and low-energy fans. Features Renovent Excellent:

- steplessly adjustable air flow rates through a control panel;
- filter indication on the appliance and the possibility for filter indication on the multiple switch;
- a completely new intelligent frost protection system which ensures that also at low outdoor temperatures the appliance's performance remains optimal and that, if necessary, it activates the standard preheater.
- low sound level
- comes as standard with automatic bypass valve
- constant flow control
- low energy consumption
- high efficiency

Renovent Excellent 300/400 is available in two types:

- **Renovent Excellent™**
- **Renovent Excellent Plus™**

Compared to the Renovent Excellent, the Renovent Excellent Plus has a more extensive control board which increases the connection options.

These installation instruction describe both the standard Renovent Excellent and the Renovent Excellent Plus.

The Renovent Excellent (Plus) is available in the left-handed or right-handed version. A left-handed version has the filters on the left behind the filter door; a right-handed version has the filters on the right behind the filtered door. The position of the air ducts differs for these two versions! For the correct position of the connection ducts and dimensions see page 5.

When ordering an appliance always state the correct type; subsequent conversion to a different version is not possible.

The Renovent Excellent comes ready to plug in with a 230 V mains plug and a connection for a low-voltage multiple switch on the outside of the appliance.

**Note:** When replacing a Renovent Large by a Renovent Excellent, do realise that the positions of the ducts "From dwelling" and "From atmosphere" are different! (only for type 4/0 & 3/1) Carefully check the position of these ducts on the basis of the connection drawings on page 5.

Version types Renovent Excellent 300/400				
Type	Version L of R	Position air ducts	Power supply	Type code
Renovent Excellent	Left-handed version	4 top connections	Power plug	4/0 L
		2 top connections & 2 bottom connections	Power plug	2/2 L
		3 top connections & 1 bottom connection	Power plug	3/1 L
	Right-hand version	4 top connections	Power plug	4/0 R
		2 top connections & 2 bottom connections	Power plug	2/2 R
		3 top connections & 1 bottom connection	Power plug	3/1 R
Renovent Excellent Plus	Left-handed version	4 top connections	Power plug	4/0 L+
		2 top connections & 2 bottom connections	Power plug	2/2 L+
		3 top connections & 1 bottom connection	Power plug	3/1 L+
	Right-hand version	4 top connections	Power plug	4/0 R+
		2 top connections & 2 bottom connections	Power plug	2/2 R+
		3 top connections & 1 bottom connection	Power plug	3/1 R+

## Technical information

	Renovent Excellent 400			
Supply voltage [V/Hz]	230/50			
Protection degree	IP30			
Dimensions (w x h x d) [mm]	675 x 765 x 564			
Duct diameter [mm]	Ø180			
External diameter condensate discharge [mm]	Ø32			
Weight [kg]	38			
Filter class	G3 (F7 optional for supply)			
Fan setting (factory setting)		1	2	3
Ventilation capacity [m³/h]	50	100	200	300
Permissible resistance ducts system [Pa]	3 - 6	6 - 20	25 - 49	56 - 178
Rated power (excl. preheater)[W]	8,6	9.5 - 15	29 - 40	72 - 98
Rated current (excl. preheater)[AA]	0,10	0.12 - 0.14	0.24 - 0.31	0.51 - 0.7
Max. rated current (with preheater switched on) [A]	6			
Cos φ	0,38	0.45 - 0.40	0.56 - 0.58	0.60 - 0.61

## Packaging

Packaging unit per pallet
2

## Warranty period

2 years on parts and 5 years on the heat exchanger.

## Sound power

Sound power Excellent 400												
Ventilation capacity [m³/h]		100		200		225		300			400	
Sound power level L <sub>w</sub> (A)	Static pressure [Pa]	9	40	38	80	47	100	84	175	240	150	225
	Housing emission [dB(A)]	28.5	31.5	39.5	40.5	42.5	46.5	50.0	52.0	53.0	53.5	56.0
	Duct "from dwelling" [dB(A)]	30.5	33.5	45.5	47.0	47.5	49.0	55.5	56.0	57.0	58.0	59.0
	Duct "to dwelling" [dB(A)]	41.5	46.5	56.0	58.0	59.5	61.5	65.0	67.5	68.5	69.5	70.5

*In practice, the value may deviate 1 dB(A) as a result of measuring tolerances*

Fan graphs

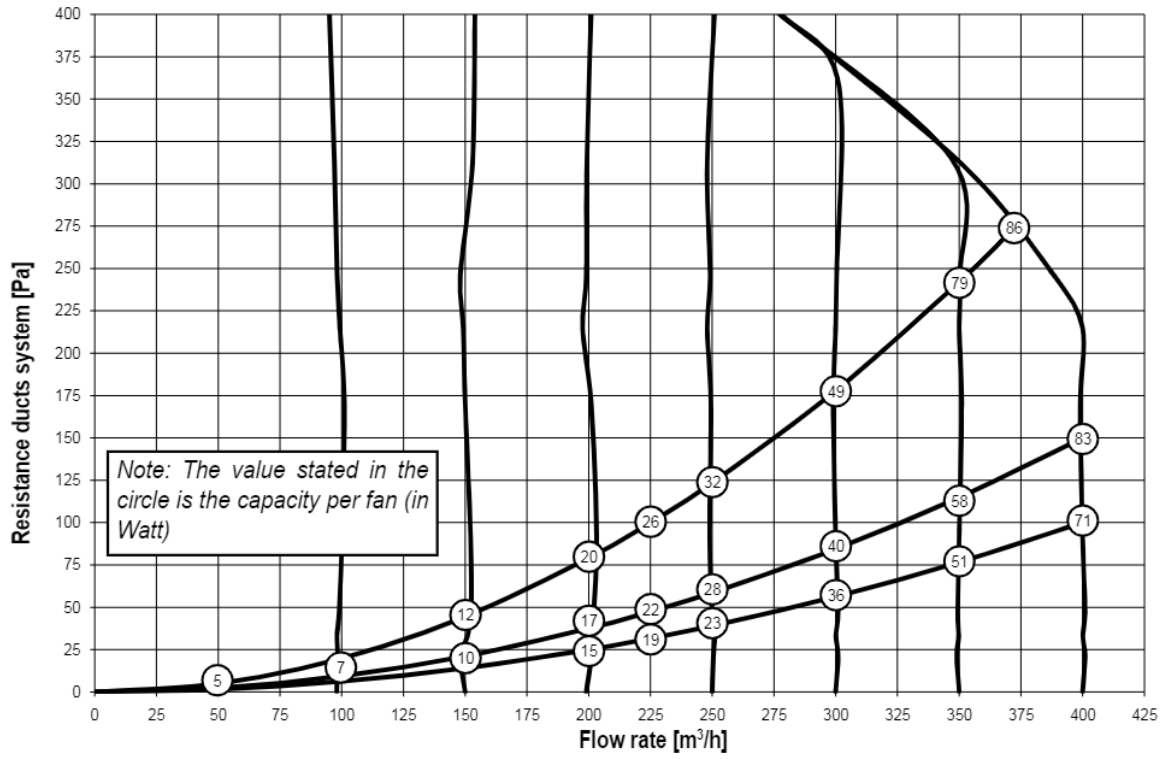

Fan graph Renovent Excellent 400

**Connections and dimensions Renovent Excellent 300/400**



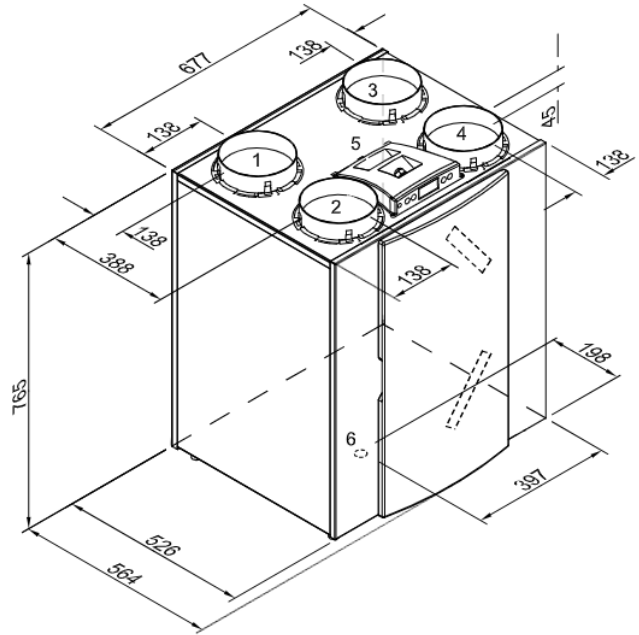
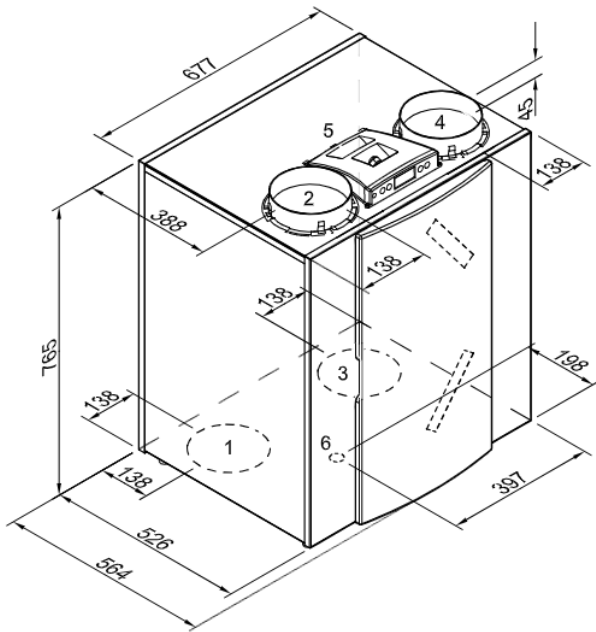

**Renovent Excellent right-handed version**

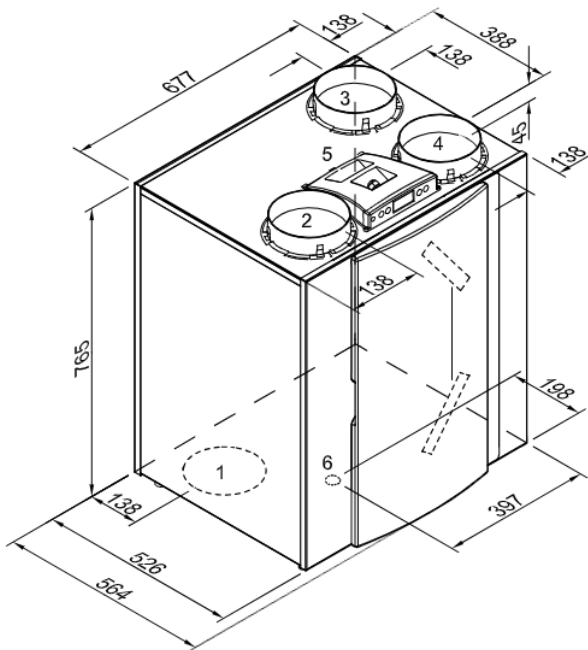

Renovent Excellent Right-handed 2/2

Renovent Excellent Right-handed 4/0



- 1 = To dwelling 
- 2 = To atmosphere 
- 3 = From dwelling 
- 4 = From atmosphere 

- 5 = Electric connections
- 6 = Connection condensate discharge

Renovent Excellent Right-handed 3/1

- 7 = Wall mounting bracket (note the correct position of the rubber strip, washers and caps)

**Renovent Excellent left-handed version**

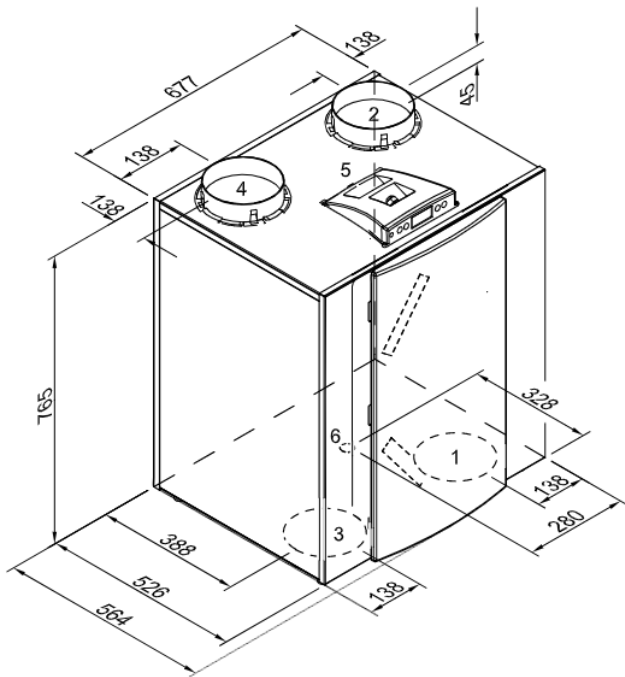

Renovent Excellent left-handed 2/2

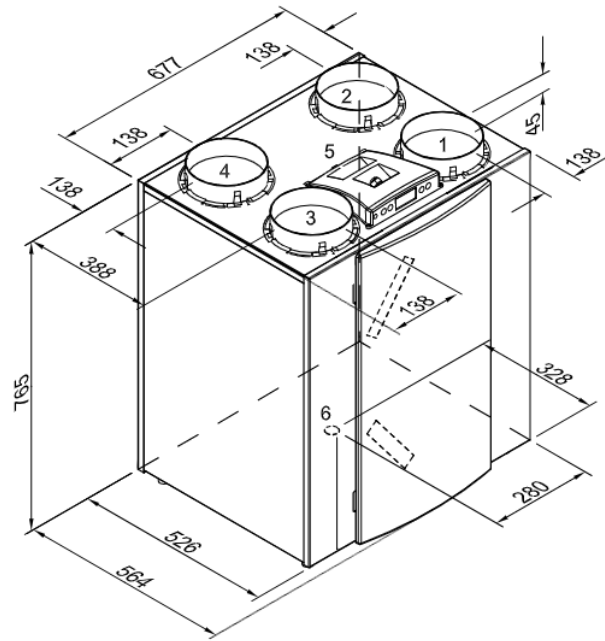

Renovent Excellent left-handed 4/0

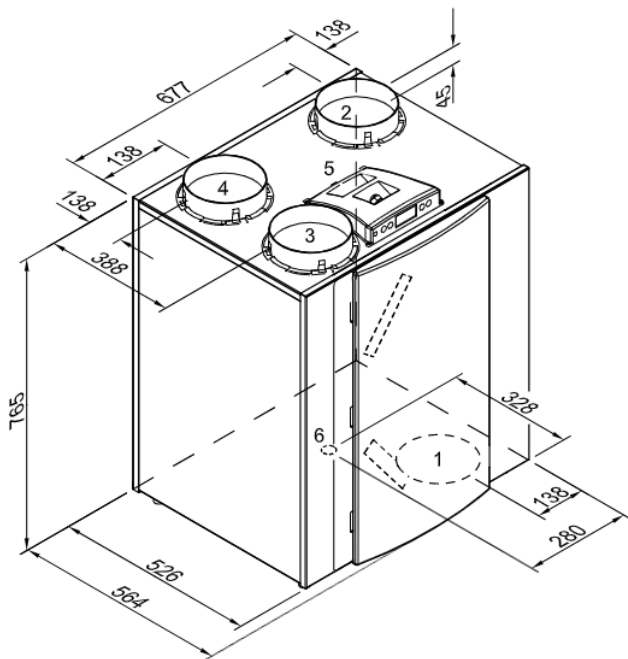

Renovent Excellent left-handed 3/1

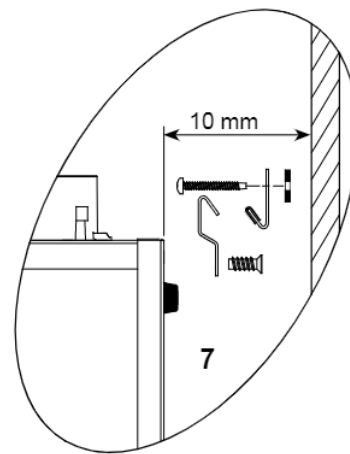

Mounting wall suspension kit

## Exploded view

When ordering parts, in addition to the article code number (see exploded view), please state the type of the heat recovery appliance, the serial number, the year of production and the name of the part:

### N. B.:

Appliance type, serial number and year of production are stated on the identification plate on the top of the appliance.

Example	
Appliance type	: Renovent Excellent 4/0 R
Serial number	: 420020113201
Year of production	: 2013
Part	: Fan
Article code	: 531774
Qty	: 1

## Service parts

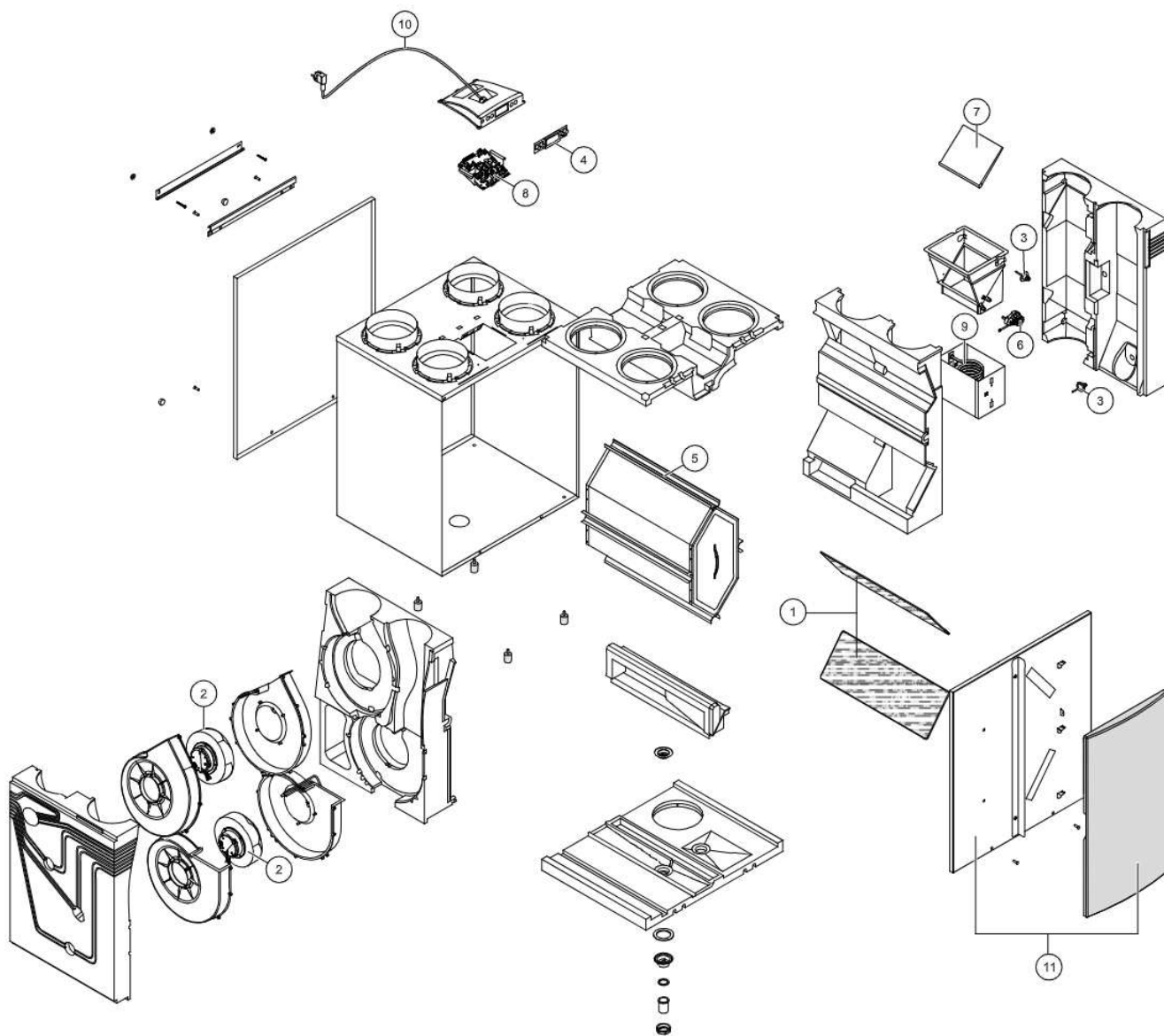

## Service parts

No.	Article description	Article code
1	Filter kit 2x G3 filter (standard version)	531770
2	Fan Excellent 300 (1 pcs)	532003
	Fan Excellent 4300 (1 pcs)	531774
3	Temperature sensor	531775
4	Control panel	531776
5	Heat exchanger Excellent 300	531840
	Heat exchanger Excellent 400	531777
6	Motor bypass valve	531778
7	Bypass valve	531779
8	Control board (Plus version) When replacing, note the correct dip switch settings; see §8.1	531780
9	Heating coil 1000 W preheater	531781
10	Cable with power plug 230 volt with display cover*	531782
11	Filter door left	531934
	Filter door right	531935

- \* The mains cable has a print connector.  
 When replacing it, always order a replacement mains cable Brink  
**To avoid dangerous situations, a damaged mains should only be replaced by a qualified person!**



## DIBt: Renovent Excellent 400

**Algemene  
bauaufsichtliche  
Zulassung**

Zulassungnummer:  
**Z-513-274**

Ausgestellt für:  
**Brink Climate Systems B.V.**  
R.D. Bögeltstraat 3  
7951 DA Staphorst  
NEDERLAND

Zulassungsgegenstand:  
**Zentrale Lüftungseinheit mit Wärmerückgewinnung "Renovent Excellent 400"**

Der oben genannte Zulassungsgegenstand wird gemäß allgemeiner bauaufsichtlicher Zulassung.  
Diese allgemeine bauaufsichtliche Zulassung umfasst nur den System- und solche Anlagen.



**Deutsches Institut für Bautechnik**

Zulassungsgemeinschaft für Bauelemente und Bauteile  
Bauteiltechnisches Prüfamt

Einzelne Bauteile sind den Landesbauverordnungen gegenüberzustellen. Bauteile, die die Bauteiltechnische Zulassung des DIBt, der DIBt und der VDI 4000 entsprechen, sind zulässig.

Datum: 18.02.2012  
Nachrichtennummer: 01 87 1 81 3 58 31

Geltungsdauer:  
vom 18. Februar 2012  
bis 18. Februar 2018



DIBt | Kolumbusstraße 35 | D-10585 Berlin | Tel.: +49 30 910310 | Fax: +49 30 910311 | E-Mail: info@DIBt.de | www.DIBt.de

## EN 308/EN 13141-7: Renovent Excellent 400

**TNO** innovation  
for life

Declaration of Conformity according to EN 13141-7:2004 / EN308

TNO-080-DTM-2010-01161  
Determination of the energetic efficiency of the energy recovery appliance "Renovent Excellent 400"  
Test report in accordance with EN 13141-7:2004 / EN308

Date: May 2012

Author(s): H.A.J. Hermans

Scanner: Brink Climate Systems B.V.  
R.D. Bögeltstraat 3  
7951 DA Staphorst

Project number: 080-01102

Keywords: heat recovery efficiency

All rights reserved.  
No part of this publication may be reproduced and/or published by print, photograph, microfilm or any other means without the previous written consent of TNO.

In case the report was drafted on instructions, the rights and obligations of contracting parties are subject to either the General Terms and Conditions for commissioning by TNO, or the relevant agreement concluded between the contracting parties. Submitting the report for inspection to parties who have a direct interest is permitted.

© 2012 TNO

Technical Sciences  
Lelystadseweg 10, Postbus 501  
7204 DT Apeldoorn  
Postbus 542  
7200 AH Apeldoorn  
www.tno.nl  
T +31 88 586 22 12  
F +31 88 586 22 40  
info@tno.nl

## NEN 5138: Renovent Excellent 400

**Verklaring conform norm**

**BRR 060-APD-2011-00014**

Bepaling van het energetische rendement van het warmteterugwinapparaat "Renovent Excellent 400"  
Meetbrief volgens NEN 5138-2004

Datum: Januari 2011

Auteur(s): G.J. Aflink

Oprachtgever: Brink Climate Systems B.V.  
R.D. Bögeltstraat 3  
7951 DA STAPHORST

Projectnummer: 034.23261/01.01

Trefwoorden: warmteterugwinning rendement

Alle rechten voorbehouden.  
Niets uit deze uitgave mag worden vernoemd, verspreid of/of openbaar gemaakt door middel van druk, foto-kopie, microfilm of op welke andere wijze dan ook, zonder voorafgaande toestemming van TNO.

Indien dit rapport in opdracht werd uitgebracht, wordt voor de rechten en verplichtingen van opdrachtgever en opdrachtnemer verwezen naar de Algemene Voorwaarden voor opdrachten aan TNO, dan wel de betreffende terzake tussen de partijen gesloten overeenkomst. Het ter inzage geven van het TNO-rapport aan direct belanghebbenden is toegestaan.

© 2011 TNO

Laan van Westenenk 501  
Postbus 342  
7300 AH Apeldoorn  
www.tno.nl  
T +31 88 86 62212  
F +31 88 86 62248

## Passive House Certificate: Renovent Excellent 400

**Certificate**  
Passive House suitable component  
For cool, temperate climates, valid until 31 December 2013

Category: Heat recovery unit  
Manufacturer: Brink Climate Systems B.V.  
7951 -DA Staphorst, NETHERLANDS  
Product name: Renovent Excellent 400 4/0 (3/1) (Plus)

This certificate was awarded based on the following criteria:

Thermal comfort	$\theta_{\text{supply air}} \geq 16.5 \text{ }^\circ\text{C}$ at $\theta_{\text{outside air}} = -10 \text{ }^\circ\text{C}$
Effective heat recovery rate	$\eta_{\text{eff,air}} \geq 75\%$
Electric power consumption	$P_{\text{el}} \leq 0.45 \text{ Wh/m}^3$
Airtightness	Interior and exterior air leakage rates less than 3% of nominal air flow rate
Balancing and adjustability	Air flow balancing possible: yes Automated air flow balancing: yes
Sound insulation	Sound pressure level $L_{\text{p}} \leq 35 \text{ dB(A)}$ based on a 4 m <sup>2</sup> equivalent absorption area not met. Here $L_{\text{p}} = 51.5 \text{ dB(A)}$ Unit should be installed so that it is acoustically separated from living areas.
Indoor air quality	Outdoor air filter F7 Extract air filter G4
Frostprotection	Frost protection for the heat exchanger with continuous fresh air supply down to $\theta_{\text{outside air}} = -15 \text{ }^\circ\text{C}$ <sup>1)</sup>

1) Only with additional anti freezing protection.

Further information can be found in the appendix of this certificate.



www.passivehouse.com 0503v03

Passive House Institute  
Dr. Wolfgang Feist  
64283 Darmstadt  
GERMANY

**Certified for air flow rates of**  
**77 – 290 m<sup>3</sup>/h**

$\eta_{\text{eff,air}}$   
**84%**  
(88% bei 100 m<sup>3</sup>/h)

**Electric power consumption**  
**0.29 Wh/m<sup>3</sup>**

SAP-Appendix-Q: Renovent Excellent 400

### Certificate

**Certified Passive House Component**  
For cool, temperate climates, valid until 31 December 2013

Category: **Heat recovery unit**  
 Manufacturer: **Brink Climate Systems B.V.**  
 7851 -DA Staphorst, NETHERLANDS  
 Product name: **Renovent Excellent 300 4/0 (2/1) (Plus)**

This certificate was awarded based on the following criteria:

Thermal comfort	Supply air > 16.5 °C at Supply air < -10 °C
Effective heat recovery rate	$\eta_{\text{eff,heat}} \geq 75\%$
Electric power consumption	$P_{\text{el}} \leq 0.45 \text{ Wh/m}^3$
Airtightness	Interior and exterior air leak age-factor less than 3 % of nominal air flow rate
balancing and adjustability	Air flow balancing possible: <b>yes</b> Automated air flow balancing: <b>yes</b>
Sound insulation	Sound pressure level $L_p \leq 35 \text{ dB(A)}$ based on a 4 m <sup>2</sup> equivalent absorption area (not met) Here $L_p = 47 \text{ dB(A)}$ Unit should be installed so that it is acoustically separated from living areas
Indoor air quality	Outdoor air filter at least F7 Extract air filter at least G4
Frost protection	Frost protection for the heat exchanger with continuous fresh air supply down to $T_{\text{outside}} = -15 \text{ °C}$ (1)

1) Only with additional anti-heating protection.

Further information can be found in the appendix of this certificate.

www.passivehouse.com 0532rv03

Passive House Institute  
Dr. Wolfgang Feist  
84589 Darmstadt  
GERMANY

**Certified for air flow rates of**  
**88 - 238 m<sup>3</sup>/h**

**η<sub>heat</sub>**  
**84 %**  
(88% at 78 m<sup>3</sup>/h)

**Electric power consumption**  
**0.26 Wh/m<sup>3</sup>**

Declaration of Conformity Renovent Excellent 400

### DECLARATION OF CONFORMITY

Manufacturer: **Brink Climate Systems B.V.**  
 Address: **R.O. Buijssestraat 3**  
**7851 -DA Staphorst, The Netherlands**

Product: **Heat recovery unit type**  
**Renovent Excellent 300/400**  
**Renovent Excellent 300/400 Plus**

The product described above complies with the following directives:  
 2006/95/EC (low voltage directive)  
 2004/108/EC (EMC directive)  
 RoHS 2002/95/EC (substances directive)

The product bears the CE label:

CE

Staphorst, 24.03.11

M. Huisman,  
managing director

42 Renovent Excellent

Renovent Excellent 400 - SEL-waarde 75+100 Pa

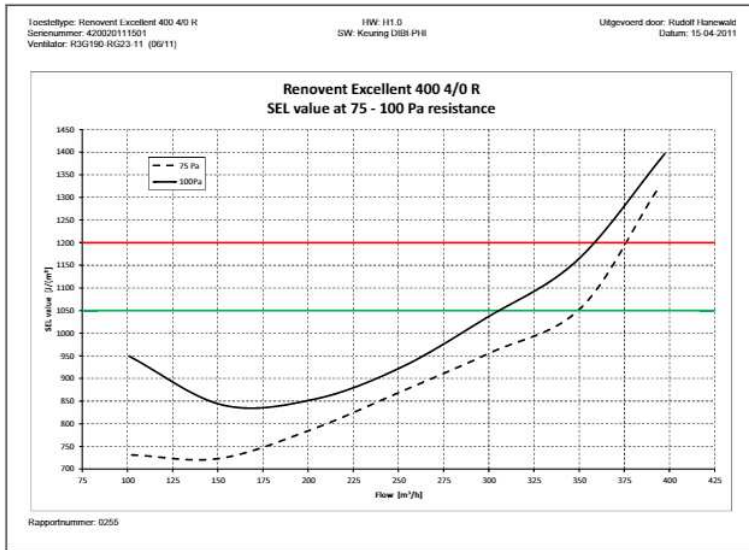

Modifications reserved

Brink Climate Systems B. V. continuously strives after improvement of products and reserves the right to change the specifications without prior notice.



**BRINK CLIMATE SYSTEMS B.V.**

P.O. Box 11 7950 AA Staphorst  
Tel. +31 (0) 522 46 99 44  
Fax +31 (0) 522 46 94 00  
info@brinkclimatesystems.nl  
www.brinkclimatesystems.nl